

1. Dryseal flat sheet: HDL H 1250F
2. Anti-corrosive fixings @ 350mm c/c max
3. Dryseal trim: HDL H 0170 JA\*
4. Tile batten
5. Lead or lead replacement flashing
6. PU adhesive bead
7. Roof tile or slate
8. Timber support
9. Mansard rafter
10. Rafter
11. Timber decking

**Note:** In-situ laminate over fixings and seams/joints omitted for clarity. Please see drawing no: JFD for more detail.

For this detail only continue laminate over the Dryseal trim bend at (3)

\* HDL H 0170 JA suitable for roof pitches up to 45°. For roof pitches above 45° please use Dryseal trim HDL H 0200A

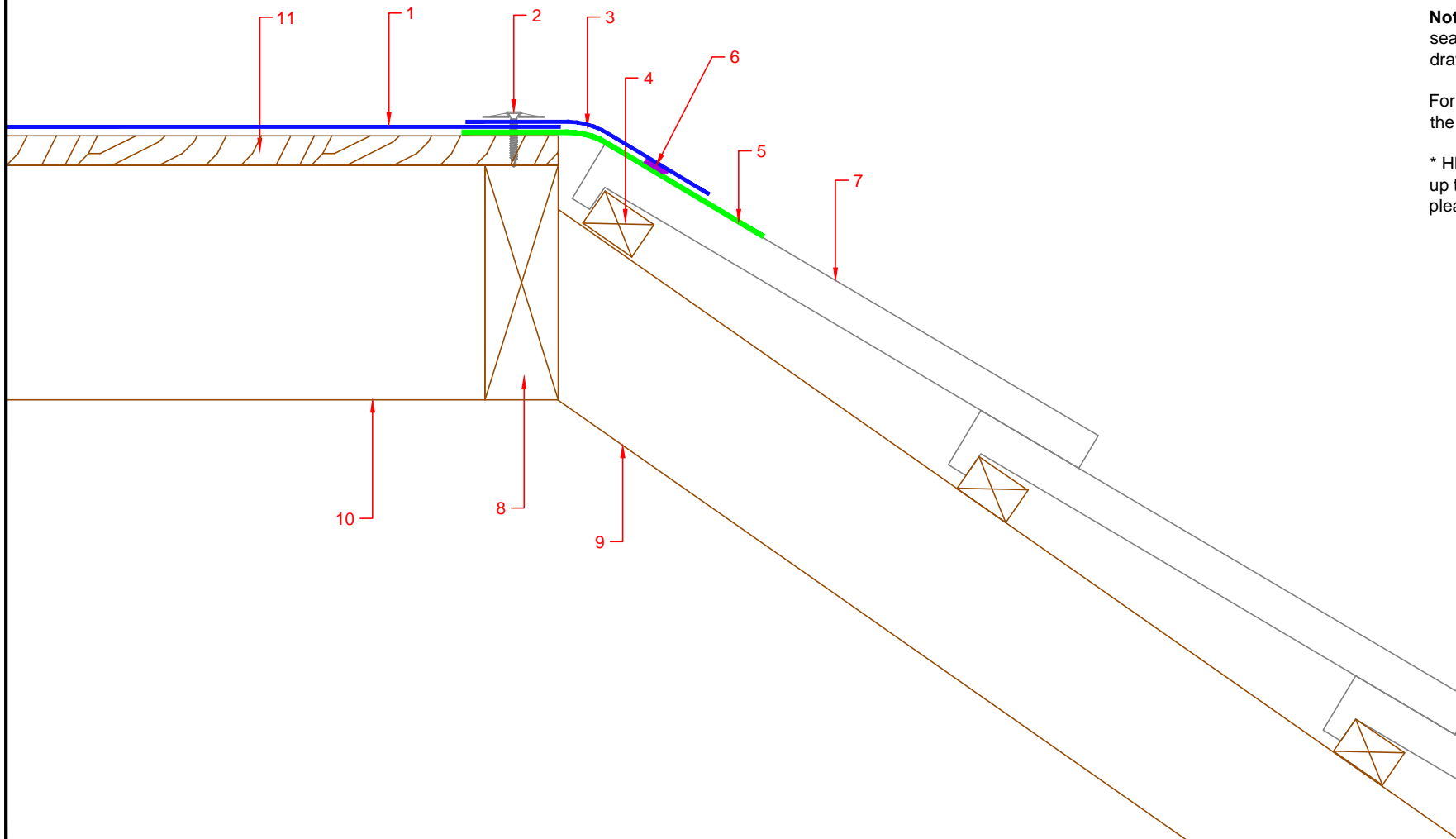

DRAWING TITLE		
Mansard Roof Edge- Cold Roof		
PROJECT		
NA		
CLIENT		
HDL		
DRAWN	DATE	SHEET
DB	12.10.2015	01
SCALE	PAPER SIZE	REVISION
NTS	A4	NA
DRAWING NO		
MCECR		
Hambleside Danelaw Ltd		
T 01327 701900		
F 01327 701909		
www.hambleside-danelaw.co.uk		
- All dimensions are in millimetres unless otherwise stated		
- All dimensions to be checked on site		
- Do not scale		
© Hambleside Danelaw Ltd, own the copyright of this document which is supplied in confidence, this document must not be used for any other purpose other than that it is supplied for.		
<b>DRYSEAL</b> <sup>®</sup>		